



Electric Energy Meter **USER MANUAL**

Meter-1S-G3
Meter-2S-G3
Meter-1T-G3
Meter-2T-G3

Legal Notice

Hoymiles has made every effort to ensure the accuracy and completeness of this manual. However, this manual may be changed and revised due to product enhancements or user feedback.

Hoymiles reserves the right to modify this manual without prior notice at any given time. The latest version of this manual can be found by visiting the Hoymiles official website www.hoymiles.com or scanning the QR Code below.



Contact Information

If you have technical queries or any questions concerning our products, please contact our support through the Hoymiles service portal:

**Germany**

service.de@hoymiles.com

Italy

service.it@hoymiles.com

Poland

service.pl@hoymiles.com

Other EU countries

service.eu@hoymiles.com

Brazil

service.br@hoymiles.com

Asia & Pacific

service.asia@hoymiles.com

Spain

service.es@hoymiles.com

Netherlands

service.nl@hoymiles.com

Finland

service.fi@hoymiles.com

USA

service.us@hoymiles.com

Spanish-speaking LA countries

service.mx@hoymiles.com

France

service.fr@hoymiles.com

Norway

service.no@hoymiles.com

Austria

service.at@hoymiles.com

Canada

service.ca@hoymiles.com

Australia & New Zealand

service.au@hoymiles.com

**Germany**

+49 6994322186

Poland

+48 918821656

France

+33 159131589

USA & Canada

+1 (205) 395-5515

Netherlands

+31 852736388

Brazil

+55 1148585231



hoymiles.com

Contents

1	About This Manual	4
1.1	Purpose	4
1.2	Audience	4
1.3	Validity	4
1.4	Symbol	4
2	Product Introduction	5
2.1	Product Appearance	5
2.2	LED Indicators	6
2.3	Main Functions	6
2.3.1	Measurement Function	6
2.3.2	Metering Function	6
2.3.3	Communication Function	6
3	Installation Instructions	12
3.1	Mechanical Installation	12
3.2	Electrical Connection	12
4	Device Maintenance	15
4.1	Troubleshooting	15
4.1.1	Abnormal Voltage, Current, and Power	15
4.1.2	Communication Fault	15
4.2	Warranty	15
5	Technical Datasheet	16

1 About This Manual

1.1 Purpose

This manual provides information on the installation, electrical connections, operation, and maintenance of the Meter-G3 series electric energy meter.

Please consider the following before installation:

- Carefully read this manual before operation.
- Keep this manual for reference.

1.2 Audience

This manual is intended for use by qualified persons only. Qualified persons must have the following skills:

- Knowledge of how an inverter works.
- Knowledge of how an electric energy meter works.
- Training in how to deal with the dangers and risks associated with the installation, maintenance, and use of electrical devices.
- Training in the installation, commissioning, and maintenance of electrical devices.
- Knowledge of and compliance with all applicable laws, standards, and directives.

1.3 Validity

This manual is valid for:

- Meter-1S-G3
- Meter-2S-G3
- Meter-1T-G3
- Meter-2T-G3

NOTE

Model identifier:

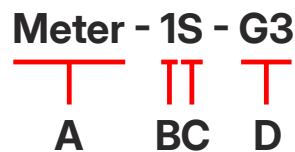

- [A]: Series Name (Electric Energy Meter)
- [B]: CT Terminal Number (One CT Terminal)
- [C]: Grid Type (Single-phase)
- [D]: Generation (The Third Generation)

1.4 Symbol

Symbol	Description
	This symbol indicates potential risks that, if not avoided, may lead to personal injury or device damage.
	This symbol indicates an important step or tip that leads to the best results but is not safety or damage related.

2 Product Introduction

The DIN-rail mounted multifunctional electric energy meter with external current transformers (CTs) is an intelligent instrument. Designed for new energy power generation systems, such as photovoltaic grid-tied systems, microinverter systems, energy storage systems, and AC-coupled systems, it is characterized by high accuracy, small size, fast response, and easy installation.

It can sample, meter, and monitor power parameters, and transmit the data to inverters. Based on real-time power and accumulated electrical energy, it supports export management, regulates power generation, and manages the battery charging and discharging processes. Additionally, it supports bidirectional metering. These functions can optimize the energy management of residential energy storage systems.

2.1 Product Appearance

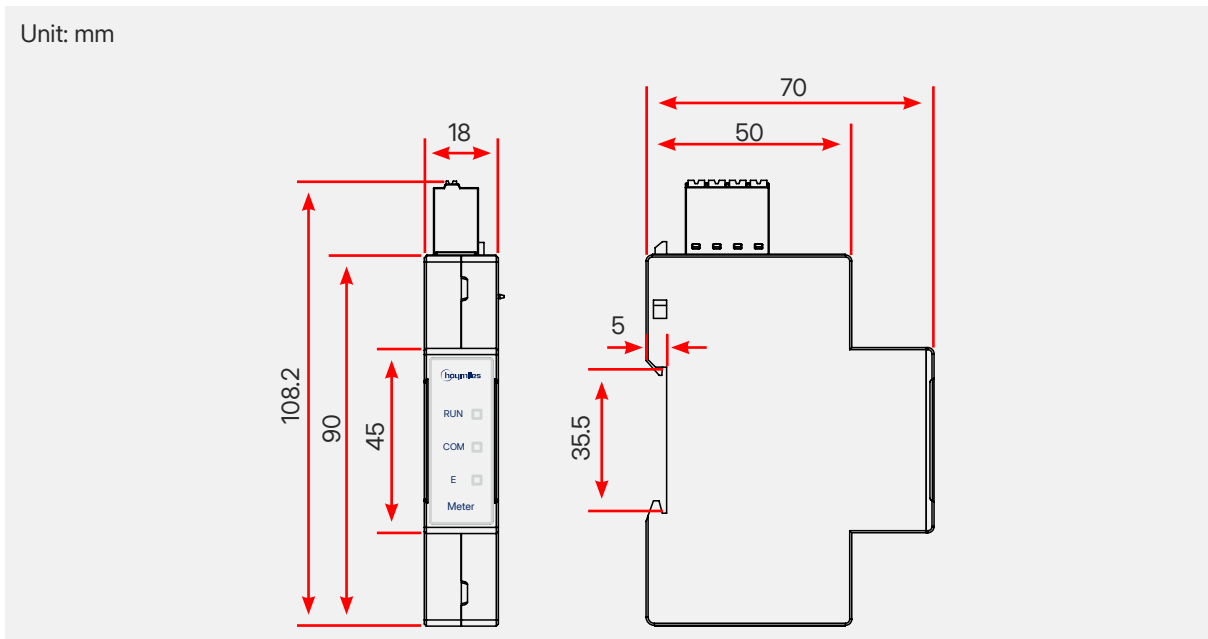

Figure 2-1 Electric Energy Meter

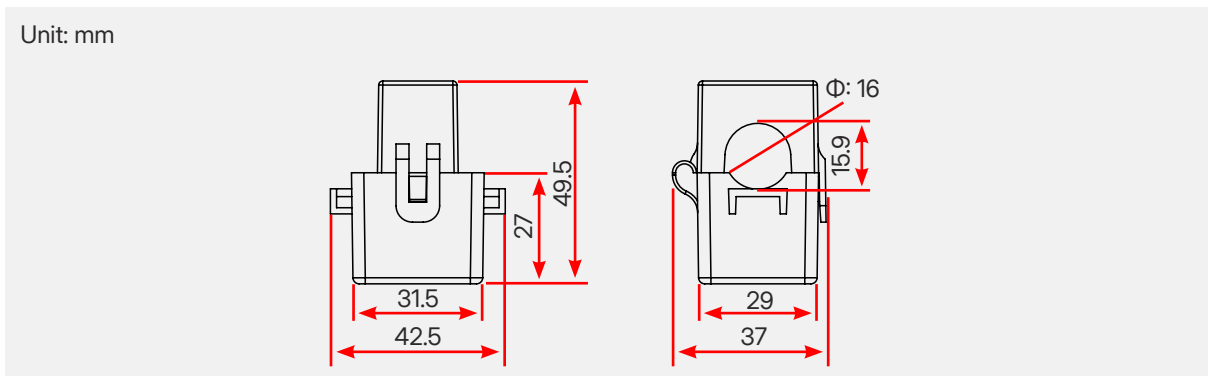

Figure 2-2 Current Transformer (CT-120 A/40 mA)

2.2 LED Indicators

Indicator	Description
RUN	Running indicator. It flashes at 1 Hz frequency during normal operation.
COM	Communication indicator. It flashes during normal communication.
E	Pulse indicator. When the pulse constant is 600, each pulse represents 1/600 kWh energy.

2.3 Main Functions

2.3.1 Measurement Function

The electric energy meter can measure all power parameters, including voltage (U), current (I), active power (P), reactive power (Q), apparent power (S), power factor (PF), frequency, forward active electric energy, reverse active electric energy, forward reactive electric energy, and reverse reactive electric energy.

2.3.2 Metering Function

The electric energy meter can meter the current combined active electric energy, forward active electric energy, reverse active electric energy, forward reactive electric energy, and reverse reactive electric energy.

2.3.3 Communication Function

The RS485 communication interface of the electric energy meter supports Modbus-RTU communication protocol. The baud rate of the communication interface can be set among 1200 bps, 2400 bps, 4800 bps, 9600 bps, 19200 bps, and 38400 bps, and the check bit is no parity.

The electric energy meter supports 03H command and 10H command in Modbus-RTU protocol. 03H command is for reading multiple registers, and 10H command is for writing multiple registers. Please check the protocol data format.

The following table shows the register address of the electric energy meter:

Table 2-1 Communication Address

Address	Name	R/W	Length (Bytes)	Type	Unit	Note
0000H	Slave address	R/W	1	Unit16	/	1-247
000BH	Feature code	R	1	Unit16	/	<ul style="list-style-type: none"> The high byte is fixed as 0xAC. The low byte represents the type of electric energy meter, as follows: 0x01: Single-channel CT - Single-phase electric energy meter; 0x02: Single-channel CT - Three-phase electric energy meter; 0x03: Dual-channel CT - Single-phase electric energy meter; 0x04: Dual-channel CT - Three-phase electric energy meter.

Address	Name	R/W	Length (Bytes)	Type	Unit	Note
000CH	The phase sequence detection result of the first channel	R	1	Unit16	/	<ul style="list-style-type: none"> The upper 8 bits (polarity of the current transformer): bit 8: Phase A bit 9: Phase B bit 10: Phase C 1 indicates that the polarity is reversed. The lower 8 bits (phase sequence): 0: ABC 1: BAC 2: ACB 3: CBA 4: CAB 5: BCA
000DH	The phase sequence adjustment of the first channel	R/W	1	Unit16	/	0: ABC 1: BAC 2: ACB 3: CBA 4: CAB 5: BCA
000EH	The polarity adjustment of the current transformer of the first channel	R/W	1	Unit16	/	Bit 0: Phase A Bit 1: Phase B Bit 2: Phase C
000FH	The phase sequence detection result of the second channel	R	1	Unit16	/	<ul style="list-style-type: none"> The upper 8 bits (polarity of the current transformer): bit 8: Phase A bit 9: Phase B bit 10: Phase C 1 indicates that the polarity is reversed. The lower 8 bits (phase sequence): 0: ABC 1: BAC 2: ACB 3: CBA 4: CAB 5: BCA
0010H	The phase sequence adjustment of the second channel	R/W	1	Unit16	/	0: ABC 1: BAC 2: ACB 3: CBA 4: CAB 5: BCA
0011H	The polarity adjustment of the current transformer of the second channel	R/W	1	Unit16	/	Bit 0: Phase A Bit 1: Phase B Bit 2: Phase C

Address	Name	R/W	Length (Bytes)	Type	Unit	Note
1000H	Slave address	R/W	1	Unit16	/	1-247
1001H	Baud rate	R/W	1	Unit16	/	Default value: 9600 Settable range: 1200, 2400, 4800, 9600, 19200, 38400
1002H	Parity and stop bit	R/W	1	Unit16	/	<ul style="list-style-type: none"> The low byte represents the parity, and its settable range is as follows: 0: None (default value) 1: Odd 2: Even The high byte represents the stop bit, and its settable range is as follows: 0: 1 stop (default value) 1: 2 stop
1009H	SnNum	R/W	7	Unit16	/	ASCII
2100H	Phase A voltage	R	2	Float	V	The electric parameters of the first channel
2102H	Phase B voltage	R	2	Float	V	
2104H	Phase C voltage	R	2	Float	V	
2106H	AB-Line voltage	R	2	Float	V	
2108H	BC-Line voltage	R	2	Float	V	
210AH	CA-Line voltage	R	2	Float	V	
210CH	Phase A current	R	2	Float	A	
210EH	Phase B current	R	2	Float	A	
2110H	Phase C current	R	2	Float	A	
2112H	Phase N current	R	2	Float	A	
2114H	Phase A active power	R	2	Float	W	
2116H	Phase B active power	R	2	Float	W	
2118H	Phase C active power	R	2	Float	W	
211AH	Total active power	R	2	Float	W	
211CH	Phase A reactive power	R	2	Float	Var	
211EH	Phase B reactive power	R	2	Float	Var	
2120H	Phase C reactive power	R	2	Float	Var	
2122H	Total reactive power	R	2	Float	Var	
2124H	Phase A apparent power	R	2	Float	VA	
2126H	Phase B apparent power	R	2	Float	VA	
2128H	Phase C apparent power	R	2	Float	VA	
212AH	Total apparent power	R	2	Float	VA	
212CH	Phase A power factor	R	2	Float	/	

Address	Name	R/W	Length (Bytes)	Type	Unit	Note	
212EH	Phase B power factor	R	2	Float	/	The electric parameters of the first channel	
2130H	Phase C power factor	R	2	Float	/		
2132H	Total power factor	R	2	Float	/		
2134H	Frequency	R	2	Float	Hz		
2300H	Phase A voltage	R	2	Float	V	The electrical parameters of the second channel	
2302H	Phase B voltage	R	2	Float	V		
2304H	Phase C voltage	R	2	Float	V		
2306H	AB-line voltage	R	2	Float	V		
2308H	BC-line voltage	R	2	Float	V		
230AH	CA-line voltage	R	2	Float	V		
230CH	Phase A current	R	2	Float	A		
230EH	Phase B current	R	2	Float	A		
2310H	Phase C current	R	2	Float	A		
2312H	Phase N current	R	2	Float	A		
2314H	Phase A active power	R	2	Float	W		
2316H	Phase B active power	R	2	Float	W		
2318H	Phase C active power	R	2	Float	W		
231AH	Total active power	R	2	Float	W		
231CH	Phase A reactive power	R	2	Float	Var		
231EH	Phase B reactive power	R	2	Float	Var		
2320H	Phase C reactive power	R	2	Float	Var		
2322H	Total reactive power	R	2	Float	Var		
2324H	Phase A apparent power	R	2	Float	VA		
2326H	Phase B apparent power	R	2	Float	VA		
2328H	Phase C apparent power	R	2	Float	VA		
232AH	Total reactive power	R	2	Float	VA		
232CH	Phase A power factor	R	2	Float	/		
232EH	Phase B power factor	R	2	Float	/		
2330H	Phase C power factor	R	2	Float	/		
2332H	Total power factor	R	2	Float	/		
2334H	Frequency	R	2	Float	Hz		
3000H	Active electric energy	R	4	Double	kWh		The electric energy of the first channel
3004H	Forward active electric energy	R	4	Double	kWh		
3008H	Reverse active electric energy	R	4	Double	kWh		

Address	Name	R/W	Length (Bytes)	Type	Unit	Note	
300CH	Reactive electric energy	R	4	Double	kVarh	The electric energy of the first channel	
3010H	Forward reactive electric energy	R	4	Double	kVarh		
3014H	Reverse reactive electric energy	R	4	Double	kVarh		
3018H	Apparent electric energy	R	4	Double	kVAh		
301CH	Active electric energy of phase A	R	4	Double	kWh		
3020H	Forward active electric energy of phase A	R	4	Double	kWh		
3024H	Reverse active electric energy of phase A	R	4	Double	kWh		
3028H	Reactive electric energy of phase A	R	4	Double	kVarh		
302CH	Forward reactive electric energy of phase A	R	4	Double	kVarh		
3030H	Reverse reactive electric energy of phase A	R	4	Double	kVarh		
3034H	Active electric energy of phase B	R	4	Double	kWh		
3038H	Forward active electric energy of phase B	R	4	Double	kWh		
303CH	Reverse active electric energy of phase B	R	4	Double	kWh		
3040H	Reactive electric energy of phase B	R	4	Double	kVarh		
3044H	Forward reactive electric energy of phase B	R	4	Double	kVarh		
3048H	Reverse reactive electric energy of phase B	R	4	Double	kVarh		
304CH	Active electric energy of phase C	R	4	Double	kWh		
3050H	Forward active electric energy of phase C	R	4	Double	kWh		
3054H	Reverse active electric energy of phase C	R	4	Double	kWh		
3058H	Reactive electric energy of phase C	R	4	Double	kVarh		
305CH	Forward reactive electric energy of phase C	R	4	Double	kVarh		
3060H	Reverse reactive electric energy of phase C	R	4	Double	kVarh		
3100H	Active electric energy	R	4	Double	kWh		The electric energy of the second channel
3104H	Forward active electric energy	R	4	Double	kWh		

Address	Name	R/W	Length (Bytes)	Type	Unit	Note
3108H	Reverse active electric energy	R	4	Double	kWh	The electric energy of the second channel
310CH	Reactive electric energy	R	4	Double	kVarh	
3110H	Forward reactive electric energy	R	4	Double	kVarh	
3114H	Reverse reactive electric energy	R	4	Double	kVarh	
3018H	Apparent electric energy	R	4	Double	kVAh	
311CH	Active electric energy of phase A	R	4	Double	kWh	
3120H	Forward active electric energy of phase A	R	4	Double	kWh	
3124H	Reverse active electric energy of phase A	R	4	Double	kWh	
3128H	Reactive electric energy of phase A	R	4	Double	kVarh	
312CH	Forward reactive electric energy of phase A	R	4	Double	kVarh	
3130H	Reverse reactive electric energy of phase A	R	4	Double	kVarh	
3134H	Active electric energy of phase B	R	4	Double	kWh	
3138H	Forward active electric energy of phase B	R	4	Double	kWh	
313CH	Reverse active electric energy of phase B	R	4	Double	kWh	
3140H	Reactive electric energy of phase B	R	4	Double	kVarh	
3144H	Forward reactive electric energy of phase B	R	4	Double	kVarh	
3148H	Reverse reactive electric energy of phase B	R	4	Double	kVarh	
314CH	Active electric energy of phase C	R	4	Double	kWh	
3150H	Forward active electric energy of phase C	R	4	Double	kWh	
3154H	Reverse active electric energy of phase C	R	4	Double	kWh	
3158H	Reactive electric energy of phase C	R	4	Double	kVarh	
315CH	Forward reactive electric energy of phase C	R	4	Double	kVarh	
3160H	Reverse reactive electric energy of phase C	R	4	Double	kVarh	

3 Installation Instructions

3.1 Mechanical Installation

Step 1 Push the buckle of the meter upward. There will be a “Click” sound when it is in place.

Step 2 Install the meter on the DIN rail.

Step 3 Push the buckle downward to lock the installation. There will be a “Click” sound when it is in place.

Step 4 Place the meter and DIN rail in or near the distribution box, behind the utility meter.



Figure 3-1 Mechanical Installation

3.2 Electrical Connection

NOTE

- For a single-phase meter, the lead wire color of the CT is yellow (L).
- For a three-phase meter, the lead wire colors of the CTs are yellow (L1), green (L2), and red (L3).
- For a single-phase grid, respectively connect the meter’s terminal L1 and N to the Grid L and N wires.
- For Meter-1S-G3 and Meter-1T-G3, connect the CT to the meter’s CT1 terminal. (The meter’s CT2 terminal is sealed.)
- In an AC-coupled system, the grid side CT must be connected to the CT1 terminal, and the PV inverter side CT must be connected to the CT2 terminal.
- This section takes Meter-1T-G3 and Meter-2T-G3 connections as an example.

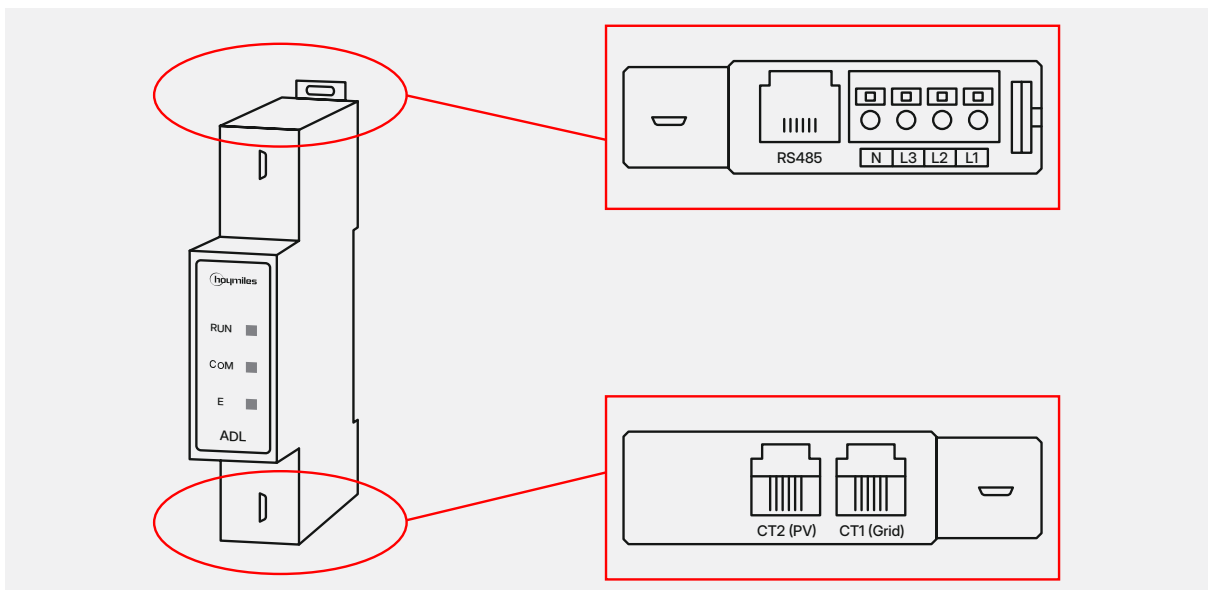



Figure 3-2 Overview

Terminal	PIN	Definition							
		1	2	3	4	5	6	7	8
RS485		NC	NC	NC	485A	485B	GND	NC	NC

NOTE
 The cable to connect the meter's RS485 terminal and the inverter's meter terminal should be a standard CAT 5E or CAT 6 Ethernet cable.

Hybrid System

Step 1 Connect meter's terminals L1, L2, L3, and N to Grid L1, L2, L3, and N.

Step 2 Clamp three CTs to Grid L1, L2, and L3.

Step 3 Connect three CTs to the meter's CT terminal (CT1). The arrows on the surface of CTs should point to the Grid.

Step 4 Use a standard Ethernet cable to connect the meter's RS485 terminal and the inverter's meter terminal.

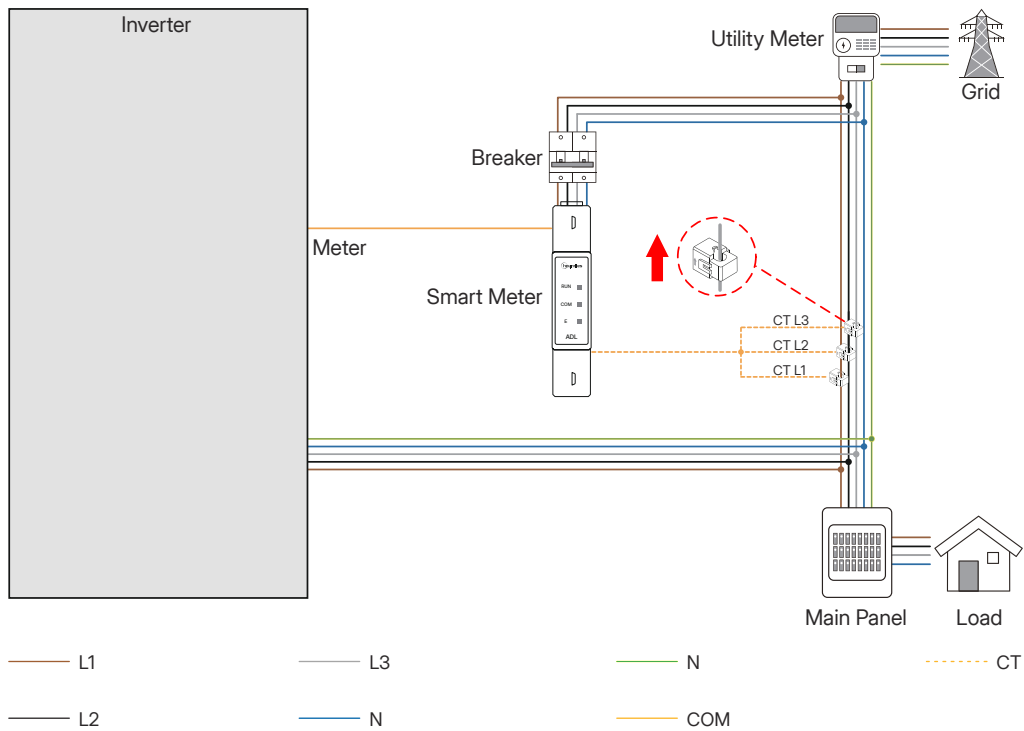

Figure 3-3 Hybrid System

WARNING
 For safety reasons, a circuit breaker with a rated current of 10 A or less should be connected to the voltage input terminal.

NOTE

- Different inverters have different wiring. For details, refer to the inverter user manual.
- The cable colors shown here are for reference only. Please comply with local laws and regulations.

AC-coupled System

- Step 1** Connect meter’s terminals L1, L2, L3, and N to Grid L1, L2, L3, and N.
- Step 2** Clamp grid side CTs to Grid L1, L2, and L3.
- Step 3** Connect grid side CTs to the meter’s CT1 terminal. The arrows on the surface of CTs should point to the Grid.
- Step 4** Clamp PV inverter side CTs to L1, L2, and L3.
- Step 5** Connect PV inverter side CTs to the meter’s CT2 terminal. The arrows on the surface of CTs should point to the opposite direction of the PV inverter.
- Step 6** Use a standard Ethernet cable to connect the meter’s RS485 terminal and the inverter’s meter terminal.

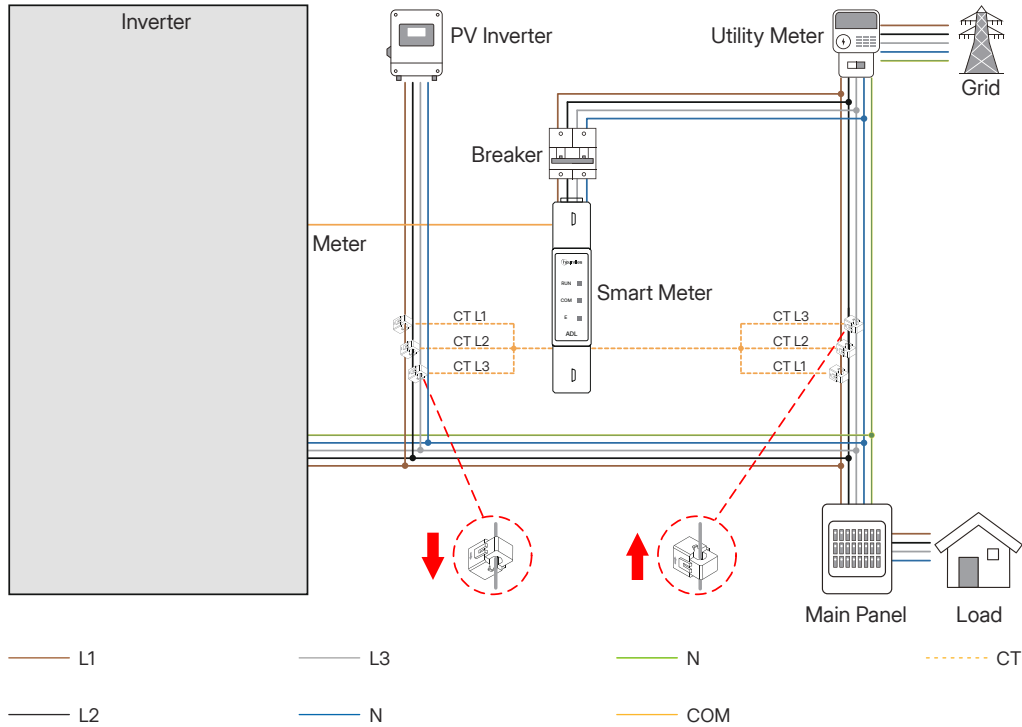

Figure 3-4 AC-coupled System

⚠ WARNING

For safety reasons, a circuit breaker with a rated current of 10 A or less should be connected to the voltage input terminal.

📘 NOTE

- Different inverters have different wiring. For details, refer to the inverter user manual.
- The cable colors shown here are for reference only. Please comply with local laws and regulations.

4 Device Maintenance

4.1 Troubleshooting

4.1.1 Abnormal Voltage, Current, and Power

WARNING

To ensure personal safety, disconnect the signal current and voltage before inspecting the current and voltage circuits.

Step 1 Inspection

- Check whether the wiring meets the requirements of the wiring diagram shown in [3.2 Electrical Connection](#).
- Check whether the voltage wiring sequence is correct.
- Check whether the direction of the secondary winding of the CT is correct.
- Check whether the phase sequence of the CT is correct.

If the above check items are correct, proceed to **Step 2**.

Step 2 Measurement

Use a multimeter in continuity test mode to measure the external circuit connections related to the problem, and check for continuity between the terminals of the external circuit and the instrument terminals.

4.1.2 Communication Fault

- Check whether the communication terminals are installed properly.
- Check whether the communication cables are connected properly.

If the above check items are abnormal, reinstall the communication terminals and reconnect the communication cables.

If the above check items are normal, contact Hoymiles technical support team.

4.2 Warranty

If users find any quality problems within the warranty period, Hoymiles is responsible for repairing or replacing the product for free, on the condition that users operate the product in accordance with the manual.

Warranty Period: 3 years (36 months)

The warranty Commencement Date shall be determined as follows, whichever occurs first:

- 4 months from the date of shipment from Hoymiles
- The installation date

5 Technical Datasheet

Model	Meter-1S-G3	Meter-2S-G3	Meter-1T-G3	Meter-2T-G3
Basic Data				
Grid type	Single-phase		Three-phase four-wire	
Rated input voltage (V)	230		3 × 230/400	
Input voltage range (V)	230±20%		3 × 230/400±20%	
Overload voltage (V)	1.2 times rating (continuous)/2 times rating (1s)			
Rated input current (A)	120			
Overload current (A)	1.2 times rating (continuous)/2 times rating (1s)			
Power consumption (VA)	<0.2			
Grid frequency (Hz)	50 (±0.5%)			
Response rate	≤100 ms (voltage, current, power) ≤1s (electrical energy)			
Measurement Accuracy				
Voltage	±0.5%			
Current	±0.5%			
Active power	±0.5%			
Reactive power	±0.5%			
Apparent power	±0.5%			
Active energy	Class B (split-core current transformer)			
Reactive energy	Class 2			
Electromagnetic Compatibility				
Electrostatic discharge immunity	Class III			
Electrical fast transient burst immunity	Class IV			
Surge (shock) immunity	Class IV			
Safety				
Power frequency withstand voltage (Vac)	3000, 1 min (between communication and signal input)			
Insulation resistance (MΩ)	>100 (input and output terminals to enclosure)			
Communication				
Interface	RS485			
Communication protocol	Modbus RTU			
Communication address range	Modbus RTU: 1-247			
Baud rate (bps)	1200-38400			
Environment				
Operating temperature (°C)	-40 to +70			
Storage temperature (°C)	-40 to +70			
Relative humidity	≤95%, no condensing			
Altitude (m)	≤2000			
Mechanical Data				
Dimensions (W × H × D [mm])	18 × 108.2 × 70			
Weight (g)	63.15			
Mounting	DIN rail			
Protection degree	IP20			



Hoymiles Power Electronics Inc.

 Floor 6, Building 5, 99 Housheng Road,
Gongshu District, Hangzhou 310015 P. R. China

 +86 571 2805 6101

 hoymiles.com

 service@hoymiles.com
support@hoymiles.com

